

A. HALL, Jr.
 Lathe for Clothes-Pins.

No. 196,353.

Patented Oct. 23, 1877.

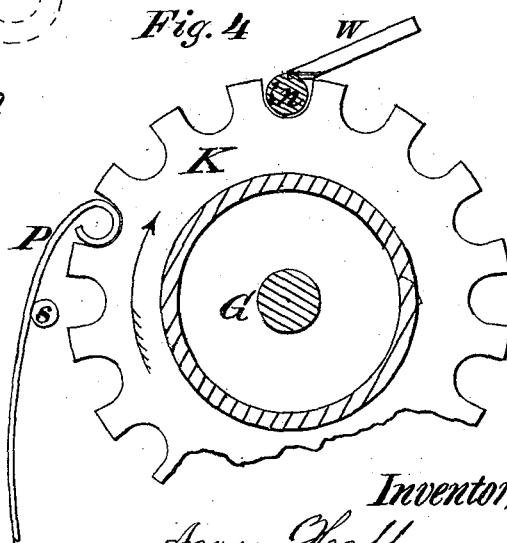
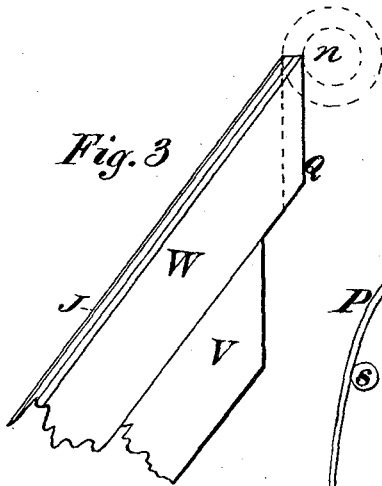
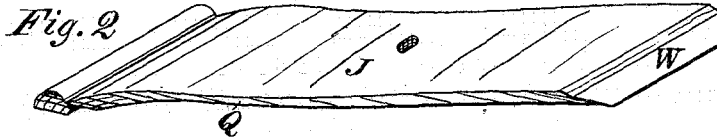
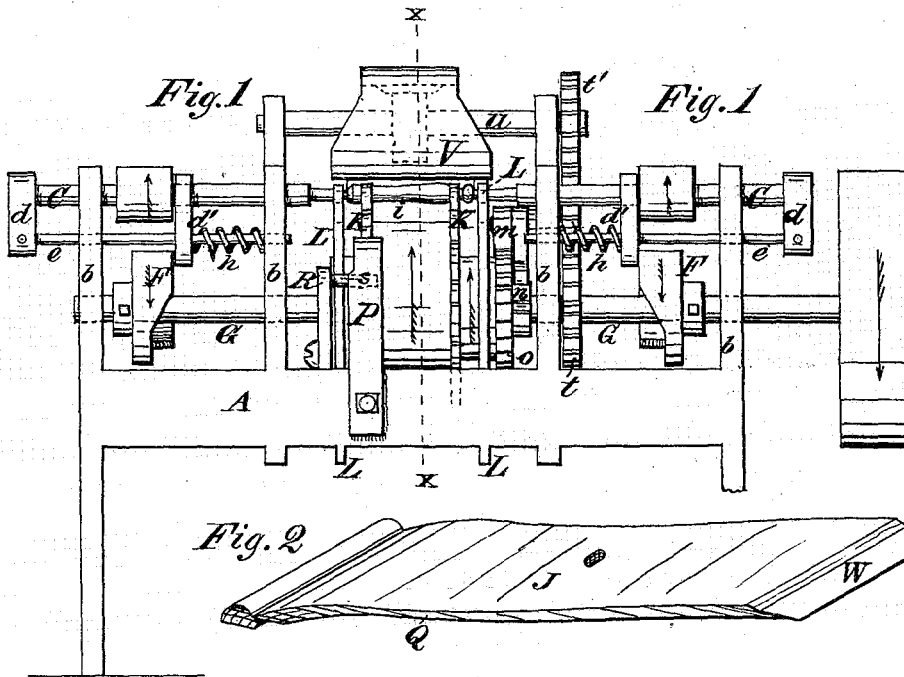

Attest:
 P. A. Latcher,
 J. A. Inaff

Inventor,
 Aaron Hall,
 By J. W. Latcher,
 Atty.

UNITED STATES PATENT OFFICE.

AARON HALL, JR., OF ST. JOHNSVILLE, NEW YORK.

IMPROVEMENT IN LATHES FOR CLOTHES-PINS.

Specification forming part of Letters Patent No. **196,353**, dated October 23, 1877; application filed March 14, 1877.

To all whom it may concern:

Be it known that I, AARON HALL, Jr., of St. Johnsville, in the county of Montgomery and State of New York, have invented a Lathe for Clothes-Pins, &c., of which the following is a specification:

This invention relates to improvements in lathes for turning clothes-pins; and consists in the construction and arrangement of the various parts of such machine, as hereinafter described and claimed.

To enable others skilled in the art to fully understand and construct my lathe, I will proceed to describe it, as follows:

Figure 1 represents a side elevation of my invention. Fig. 2 is an isometrical view of the turning-knife. Fig. 3 is an edge view of the same, showing in dotted circles the position of the clothes-pin or blank to be turned. Fig. 4 is a sectional view of the feed-wheel, taken in the line *x x*, Fig. 1.

The arrows indicate the direction of motion of the several parts; and similar letters of reference indicate corresponding parts in all the figures.

A, Fig. 1, represents the bed-frame of the lathe. *b b b b* are the head stocks or frames supporting the bearings for the spindles C C. The spindles are provided with the thrust-bearings *d d* and *d' d'*, which are secured to the rods *e e*. Cams F F are secured to the shaft G G. Said cams actuate the spindles forward or toward each other, while the springs *h h* cause the spindles to recede from each other when released by the cams F F in the usual way, the clothes-pin being shown at *i*, Fig. 1.

The intermitting rotary feed-wheels are shown in Figs. 1 and 4 at K. Said feed-wheels encircle the cam-shaft G, but do not touch it necessarily. They have independent bearings in the retracting-plates L L, said plates or frames L L being provided with small round holes, through which the spindle-chucks can pass, but too small for the entrance of the clothes-pin or other article to be turned.

The feed-wheel K is rotated by means of a pawl, *m*, and actuated by a cam or tappet, *n*, secured to the cam-shaft G. Said pawl engages with a ratchet-wheel, *o*, secured to the hub of the feed-wheels K K. A spring-catch,

P, drops into the circular recesses, (which also receive the blanks and deliver the turned clothes-pins,) as shown in Fig. 4, which retains the wheels K K at each rest in their proper positions, in order to hold the blanks, as shown at *n*, Fig. 4, to be centered by the spindle-chucks, as will be readily inferred.

Just before the feed-wheels K K are again rotated one notch the spring-catch P is raised out of the notch in said feed-wheel by means of a cam or tappet secured to the cam-shaft G, actuating an angular arm, R, to which a pin, *s*, is affixed, which raises the spring from the circular recess.

It will be observed that the feed-wheels K K and ratchet *o* have a corresponding number of notches, for obvious reasons.

A gear, *t*, is secured to the cam-shaft G, which rotates a gear, *t'*, secured to the shaft *u*, to which is secured a cam, (shown in dotted lines,) which oscillates the knife-frame V in the usual way. The knife-frame is also hinged in the usual way to the frame of the lathe in any convenient way, in order to secure rigid oscillations.

The knife represented in Figs. 2 and 3 at W is provided with two faces, as shown in Fig. 2 at J, or outer face, and Q the bevel or inner surface, against which the revolving clothes-pin revolves or wears, as shown in Fig. 3; and the bevel surface is ground away and sharpened whenever the edge becomes worn away, or becomes dull by the constant friction of the revolving clothes-pin or other article, as represented at *n*, Fig. 3, in dotted circles. The surfaces J and Q are nearly exact counterparts of the clothes-pin as to sectional contour. The surface J is not changed by grinding or otherwise; but the bevel Q is the surface that receives the grinding and sharpening, as has already been stated. The faces J and Q terminate or form a junction in the edge, which is quite straight when viewed from a point at right angles to the bevel face.

It will be understood that the knife W is a broad or finishing knife, which turns a shaving the entire length of the clothes-pin, in the usual way.

I am aware of Patent No. 144,152, and hereby disclaim the construction therein shown and described.

Having thus described my invention, what I claim as new, and desire to secure by Letters Patent, is—

1. The combination, in knives for turning, of the faces J and Q, formed as shown and described, and terminating in a straight edge, substantially as and for the purpose set forth.

2. The combination, in lathes for turning clothes-pins, of the knife W, oscillating knife-

frame V, feed-wheels K K, pawl *m*, cam *n*, ratchet *o*, catch P, and retractor-plates L L, all arranged and operating as shown and described, for the purpose set forth.

AARON HALL, JR.

Witnesses:

J. W. LATCHER,

P. A. GRAFF.